



КАТАЛОГ ЗАПЧАСТЕЙ К ДВИГАТЕЛЮ 157FM1
(4-такта, объем 125 см.куб.)

DRAGON 125 (QM125GY-2B(A))

www.SkyBike.com.ua

Внимание!

Для заказа запчастей необходимо в каталоге найти страницу с изображением интересующей вас детали. В левом верхнем углу написан код рисунка. Номер детали указан возле изображения детали. Например для заказа прокладки глушителя, для модели FORTUNE 50, вы пишете в заявке – "FIG.13 – 8 Прокладка глушителя" (или название на английском из каталога) и необходимое количество. Если группа деталей объединена скобкой, это значит, что детали продаются в комплекте.

После того, как вы определились с выбором детали, вы можете сделать заказ, уточнить наличие на складе, цену, позвонив по телефонам указанным на [сайте](#) или отправьте запрос на наш e-mail: repair@skybike.com.ua

КАТАЛОГ ЗАПЧАСТЕЙ

No.	НАЗВАНИЕ	
FIG.E1	ГОЛОВКА ЦИЛИНДРА.....	1
FIG.E2	ЦИЛИНДР.....	3
FIG.E3	КАРТЕР.....	4
FIG.E4	КРЫШКА КАРТЕРА ПРАВАЯ	6
FIG.E5	КОЛЕНВАЛ/ПОРШЕНЬ/КОЛЬЦА	8
FIG.E6	СЦЕПЛЕНИЕ.....	10
FIG.E7	РАСПРЕДВАЛ/КЛАПАНА.....	11
FIG.E8	МАСЛО-НАСОС	13
FIG.E9	ТРАНСМИССИЯ.....	15
FIG.E10	МЕХАНИЗМ ВЫБОРА ПЕРЕДАЧ.....	18
FIG.E11	МОТОР СТАРТЕРА	20
FIG.E12	МАГНЕТТО.....	21
FIG.E13	КРЫШКА КАРТЕРА ЛЕВАЯ	22
FIG.E14	КАРБЮРАТОР	24
FIG.E15	ЛАПКА КИК СТАРТЕРА.....	26
FIG.E16	КРЫШКА ДВИГАТЕЛЯ.....	27

FIG.E1

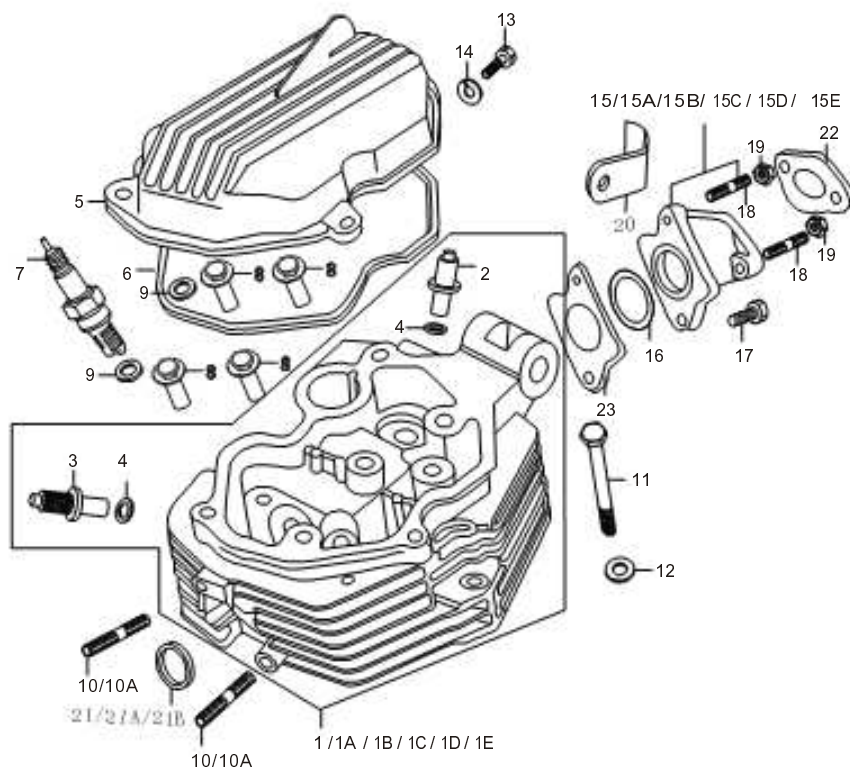

E1

FIG.E1

ГОЛОВКА ЦИЛИНДРА

Ref.No.	Part No.	Description	Q'ty	Remarks
1	157FMI.02.5-00	Cylinder head	1	
1A	157FMI.02.5-00C	Cylinder head	1	
1B	157FMI.02.5-00A	Cylinder head	1	
1C	157FMI.02.5-00E	Cylinder head	1	
1D	157FMI.02.5-00G	Cylinder head	1	
1E	157FMI.02.5-00F	Cylinder head	1	
2	157FMI.02.5-04	Intake valve guide	1	
3	157FMI.02.5-01	Outer valve guide	1	
4	157FMI.02-03	O Ring 10x1.6	2	
5	157FMI.02-11	Cover, cylinder head	1	
6	157FMI.02-12	Llimit plate	1	
7	K157FMI.02-45A	Spake plug	1	
8	157FMI.02-04	Bolt	4	
9	157FMI.02-23	Washer 12.5	2	
10	GB900-88	Bolt M6x35	2	
10A	GB900-88	Bolt M8x35	2	
11	157FMI.02-20	Bolt M8x79	1	
12	157FMI.02-24	Washer 8	1	
13	GB5787-86	Bolt M6x12	1	
14	N151FMG.02-28	Washer	1	

157FMI

FIG.E1

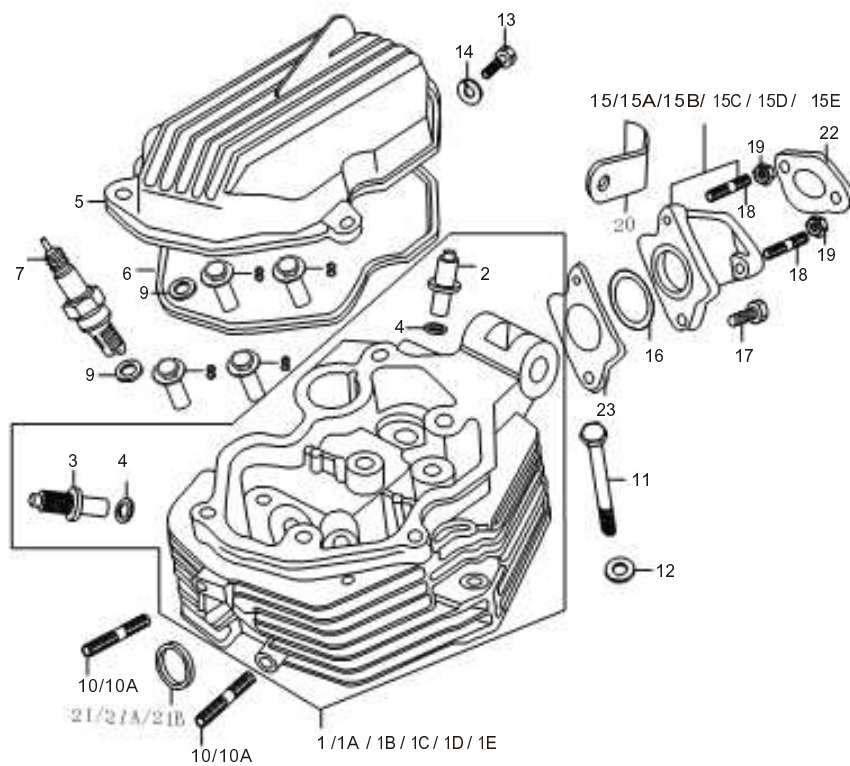

E1

FIG.E1

ГОЛОВКА ЦИЛИНДРА

Ref.No.	Part No.	Description	Q'ty	Remarks
15	157FMI.02.7-00	Inlet pipe carb comp	1	
15A	157FMI.02.7-00A	Inlet pipe carb comp	1	
15B	157FMI.02.7-00B	Inlet pipe carb comp	1	
15C	157FMI.02.7-001	et pipe carb comp	1	
15D	157FMI.02.7-00A1	Inlet pipe carb comp	1	
15E	157FMI.02.7-00B1		1	
16	157FMI.02-13	Ring 33.5x3	1	
17	GB5781-86	Bolt M6 x 20	2	
18	GB900-88	Bolt M6 x 24	2	
19	GB6170-86	Nut M6	2	
20	157FMI.01-23		1	
21	157FMI.02.8-00	Cushion, muffler	1	
21A	157FMI.02.8-00A	Cushion, muffler	1	
21B	157FMI.02.8-00B	Cushion, muffler	1	
22	157FMI.02.7-02A	Inlet pipe washer	1	
23	157FMI.02.7-02B	Inlet pipe washer	1	

157FMI

FIG.E2

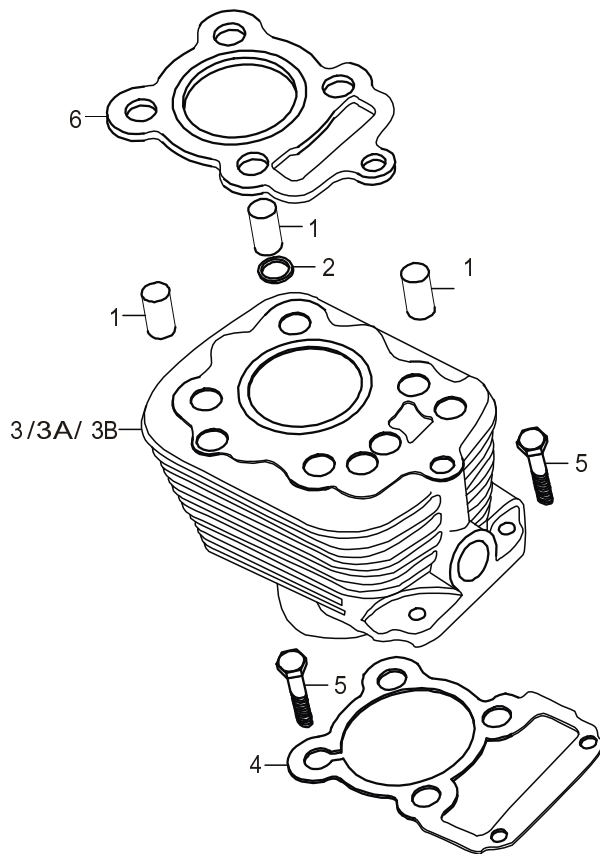

E 2

FIG.E2

ЦИЛИНДР

Ref.No.	Part No.	Description	Q'ty	Remarks
1	139QMB.01-13	Pin 10 x 20	3	
2	157FMI.02-03	O-Ring 10 x 1.6	1	
3	157FMI.02.2-00	Cylinder block assy	1	
3A	157FMI.02.2-00A	Cylinder block assy	1	
3B	157FMI.02.2-00	Cylinder block assy	1	
4	157FMI.02-05	Gasket	1	
5	GB5787-86	Bolt M6 x 25	2	
6	157FMI.02.6-00	Washer	1	

157FMI

FIG.E3

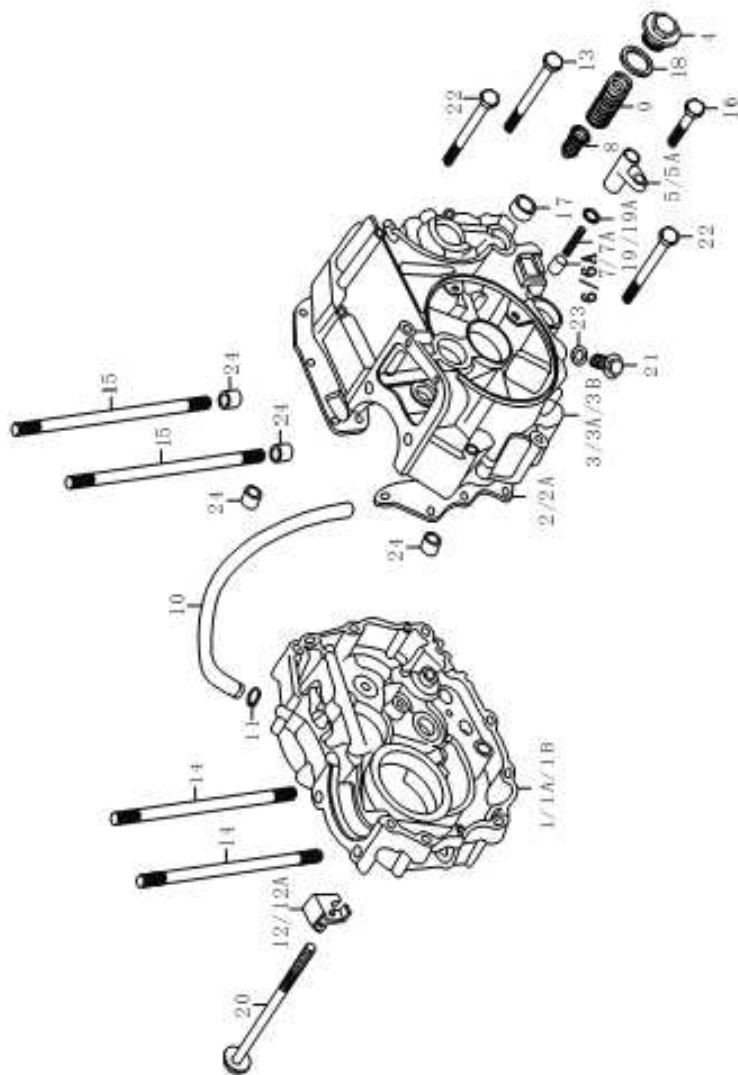

157FMI

E3

FIG.E3

KAPTEP

Ref.No.	Part No.	Description	Q'ty	Remarks
1	157FMI.01.2-00	Right piece	1	
1A	157FMI.01.2-00C	Right piece	1	
1B	157FMI.01.2-00A	Right piece	1	
2	157FMI.01-03	Gasket	1	
2A	157FMI.01-03A	Gasket	1	
3	157FMI.01.1-00	Left piece	1	
3A	157FMI.01.1-00C	Left piece	1	
3B	157FMI.01.1-00A	Left piece	1	
4	157FMI.12-02	crew cap	1	
5	157FMI.01.4-01	Supporting	1	
5A	157FMI.01.4-01A	Supporting	1	
6	157FMI.01.4-02	Plug	1	
6A	157FMI.01.4-02A	Plug	1	
7	157FMI.01.4-03	Spring	1	
7A	157FMI.01.4-03A	Spring	1	
8	139QMB.12.3-00	Screw	1	
9	157FMI.12-01	Spring	1	
10	157FMI.01-17	Air pipe	1	
11	158FMI.01-18	Circlip	1	
12	157FMI.01-11	Supporting piece	1	

FIG.E3

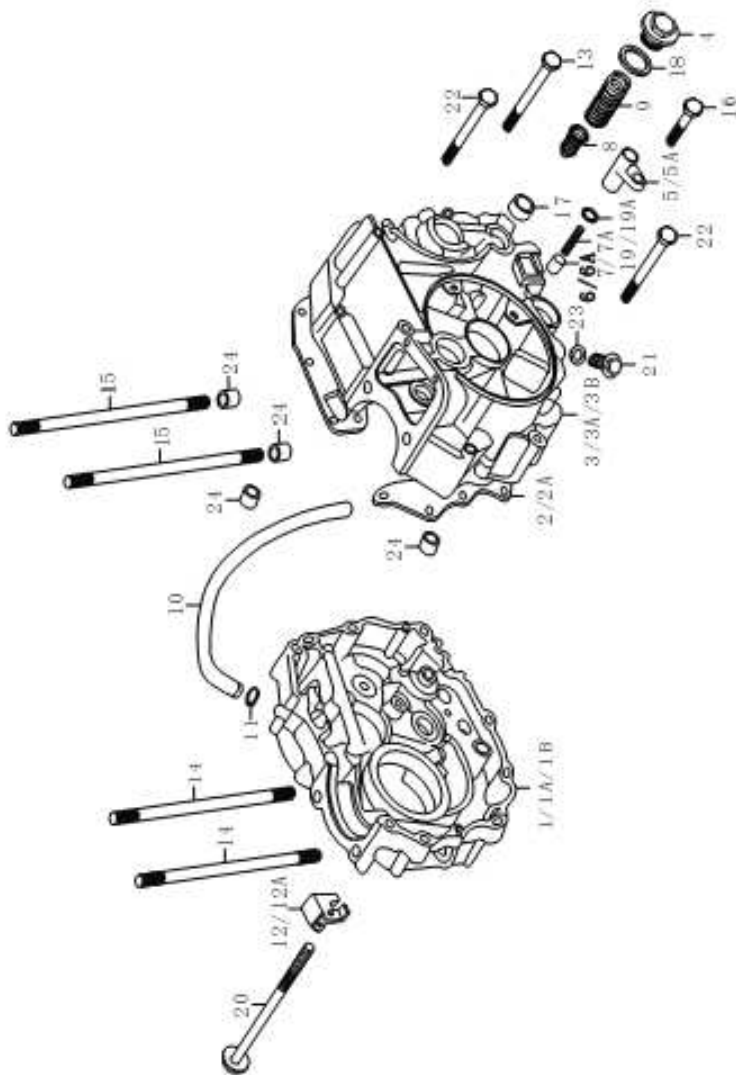

157FMI

E 3

FIG.E3

KAPTEP

Ref.No.	Part No.	Description	Q'ty	Remarks
12A	157FMI.01-11F	Supporting piece	1	
13	GB5787-86	Screw M6 x 55	1	
14	157FMI.02-02	Bolt M8 x 122	2	
15	157FMI.02-01	Bolt M8 x 130	2	
16	GB5787-86	Bolt M6 x 25	1	
17	244FMI.04-07	Oil seal 20 x 34 x 7	1	
18	157FMI.12-03	O Ring 35 x 3	1	
19	157FMI.01.4-04	O Ring 13.5 x 2.5	1	
19A	157FMI.01.4-04A	O Ring 13.5 x 2.5	1	
20	GB5787-86	Bolt M6 x 95	1	
21	244FMI01-14	Bolt M12	1	
22	GB5787-86	Bolt M6 x 50	9	
23	244FMI01-15	Washer 12	1	
24	T151QMI02-09	Bush 10 x 14	6	

FIG.E4

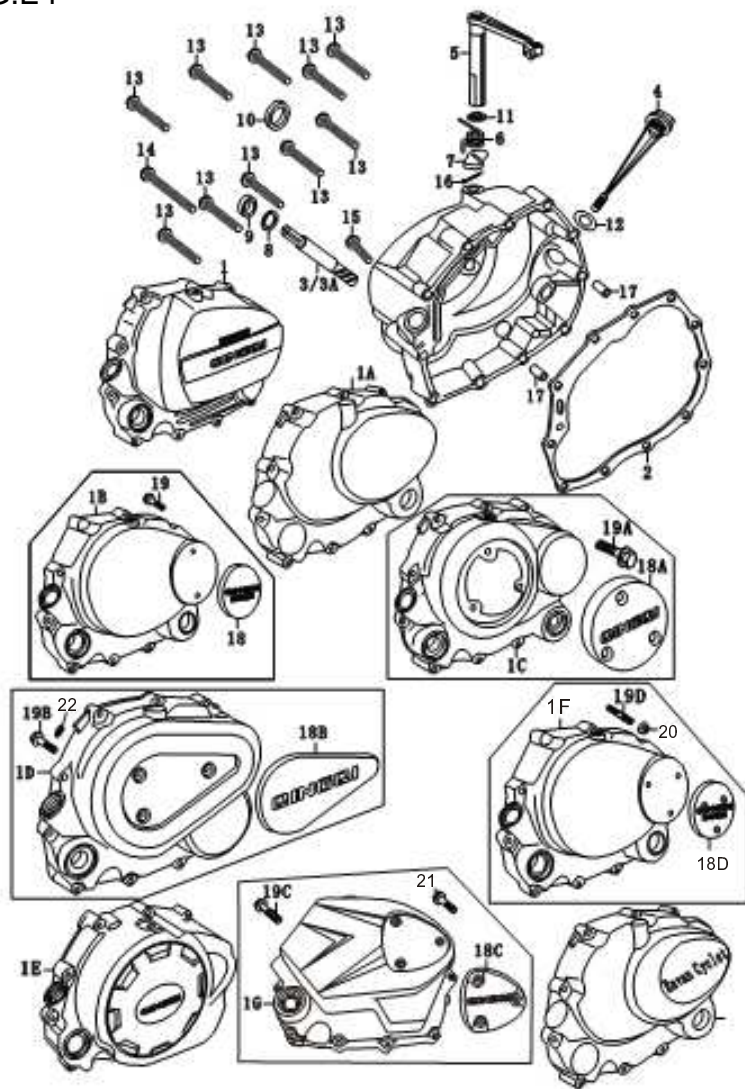

157FMI

E4

FIG.E4

КРЫШКА КАРТЕРА ПРАВАЯ

Ref.No.	Part No.	Description	Q'ty	Remarks
1	157FMI.01.3-01	Right hand case cover	1	
1A	157FMI.01.3-01A	Right hand case cover	1	
1B	157FMI.01.3-01B	Right hand case cover	1	
1C	157FMI.01.3-01J	Right hand case cover	1	
1D	157FMI.01.3-01D	Right hand case cover	1	
1E	157FMI.01.3-01E	Right hand case cover	1	
1F	157FMI.01.3-01I	Right hand case cover	1	
1G	157FMI.01.3-01F	Right hand case cover	1	
1H	157FMI.01.3-01C	Right hand case cover	1	
2	157FMI.01-04	Gaasket	1	
3	157FMI.01-12A	Gear	1	
3A	157FMI.01-12B	Gear	1	
4	M150FMG.-2.01-31	Oil lever	1	
5	157FMI.05.3-00A	Push rod, clutch	1	
5A	157FMI.05.3-00F	Push rod, clutch	1	
6	157FMI.05-02	Spring	1	
6A	157FMI.05-02P	Spring	1	
7	157FMI.05-01	Cam, clutch	1	
8	157FMI.01-25	Washer	1	
9	244FMI.01-26	Seal 6.5x14.5x7	1	
10	157FMI.06-07	Seal 16 x28 x 7	1	

FIG.E4

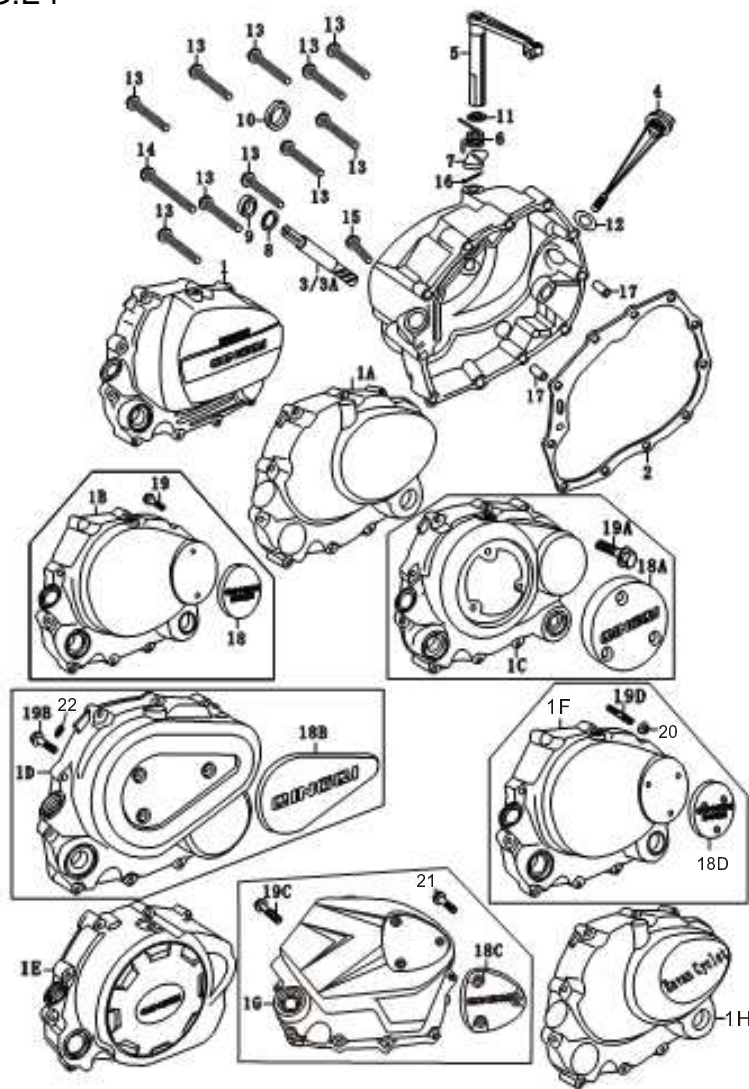

157FMI

E4

FIG.E4

КРЫШКА КАРТЕРА ПРАВАЯ

Ref.No.	Part No.	Description	Q'ty	Remarks
11	T151QMI02-03	O-Ring 6.8 x 1.9	1	
12	244FMI01-02	O-Ring 18 x 3	1	
13	GB5787-86	Screw M6 x 40	10	
14	GB5787-86	Screw M6 x 50	1	
15	GB820-85	Screw M5 x 25	1	
16	GB91-86	Pin	1	
16A	GB879-86	Pin	1	
17	157FMI.01-14	Pin 10 14	2	
18	157FMI.01-15	Brand cover, RH	1	
18A	157FMI.01-15A	Brand cover, RH	1	
18B	157FMI.01-20A	Brand cover, RH	1	
18C	157FMI.01-21F	Brand cover, RH	1	
18D	157FMI.01-20I	Brand cover, RH	1	
19	GB5787-86	Bolt M6 x 16	2	
19A	GB5789-86	Bolt M6 x 12	3	
19B	GB5783-86	Bolt M6 x 10	3	
19C	GB820-2000	Bolt M5 x 16	2	
19D	GB900-88	Bolt M6 x 24	3	
20	GB802-88	Bolt M6	3	
21	GB820-2000	Bolt M5 12	1	
22	K157FMI.01.4-00	Gasket	3	

FIG.E5

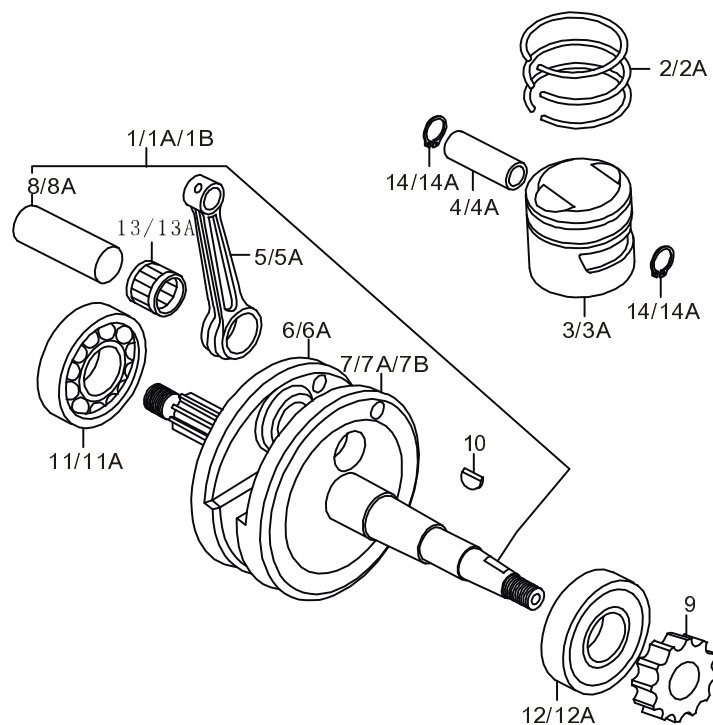

E5

FIG.E5

КОЛЕНВАЛ / ПОРШЕНЬ

Ref.No.	Part No.	Description	Q'ty	Remarks
1	157FMI.03-00A	Crankshaft assy	1	
1A	157FMI.03-00C	Crankshaft assy	1	
1B	157FMI.03-00B	Crankshaft assy	1	
2	157FMI.03-08 09.10	Piston ring set	1	
2A	08A 09A 10A	Piston ring set	1	
3	157FMI.03-07	Piston	1	
3A	157FMI.03-07A	Piston	1	
4	157FMI.03-11	Pin	1	
4A	157FMI.03-11A	Pin	1	
5	157FMI.03-03A	Conrod	1	
5A	157FMI.03-03C	Conrod	1	
6	157FMI.03-02A	Right crankshaft	1	
6A	157FMI.03-02C	Right crankshaft	1	
7	157FMI.03-01A	Left crankshaft	1	
7A	157FMI.03-01C	Left crankshaft	1	
7B	157FMI.03-01B	Left crankshaft	1	
8	157FMI.03-04A	Pin	1	
8A	157FMI.03-04B	Pin	1	
9	157FMI.03-06	Timing gear	1	
10	157FMI.03-15	Key	1	

157FMI

FIG.E5

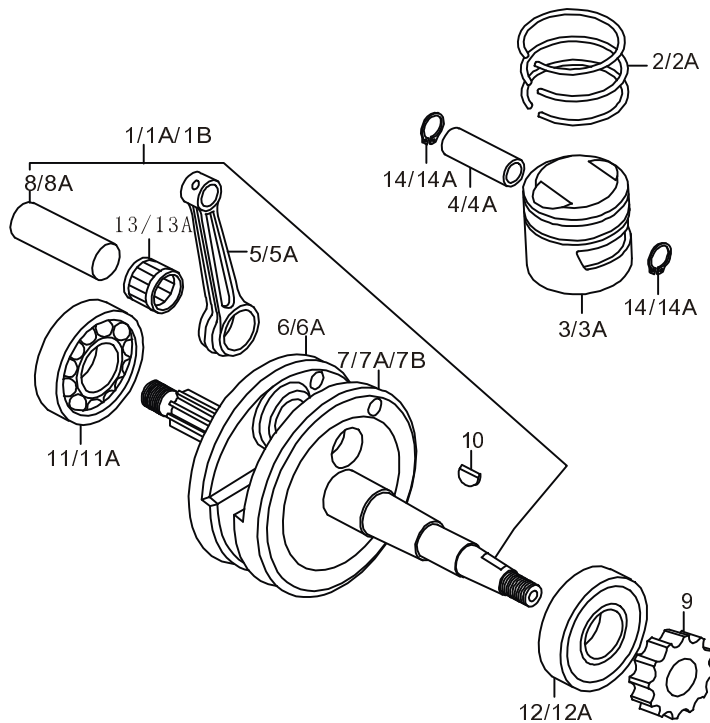

E5

FIG.E5

КОЛЕНВАЛ / ПОРШЕНЬ

Ref.No.	Part No.	Description	Q'ty	Remarks
11	E63/28C3	Bearing	1	
11A	E63/28XRC3	Bearing	1	
12	E63/28RSC3	Bearing	1	
12A	E63/28RSXRC3	Bearing	1	
13	KZK303818	Bearing KZK303818	1	
13A	KEK283616	Bearing KEK283616	1	
14	157FMI.03-12	Circlip	2	
14A	157FMI.03-12A	Circlip	2	

157FMI

FIG.E6

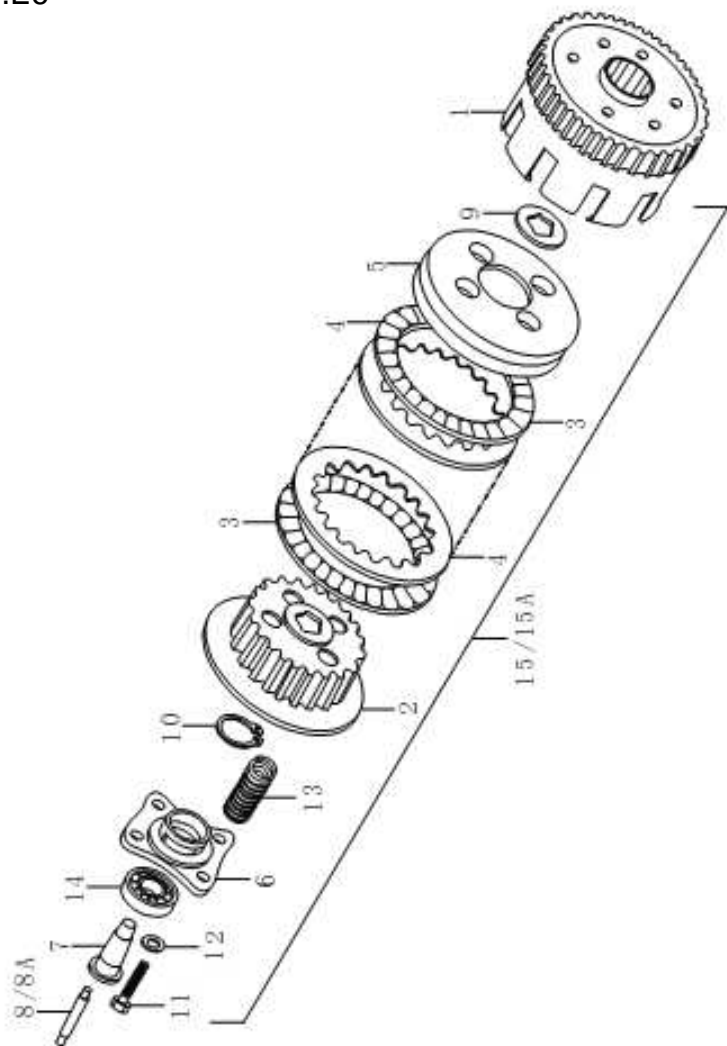

157FMI

E 6

FIG.E6

СЦЕПЛЕНИЕ

Ref.No.	Part No.	Description	Q'ty	Remarks
1	157FMI.05.1-00A	Clutch gear	1	
2	157FMI.05.2-00A	Clutch gear	1	
3	157FMI.05-08A	Clutch piece	5	
4	157FMI.05-07A	Clutch piece	4	
5	157FMI.05-09A	Locating plate	1	
6	157FMI.05-04A	Commecting plate	1	
7	157FMI.05-06A	Bush	1	
8	157FMI.05-05A	Rod	1	
8A	157FMI.05-05F	Rod	1	
9	157FMI.05-10A	Washer	1	
10	GB8941-86	Circlip	1	
11	GB5783-86	Bolt M6 x 25	4	
12	GB97.1-85	Washer 6	4	
13	157FMI.05-03A	Spring	4	
14	GB/T276-86	Bearing 6001	1	
15	157FMI.05-00A	Clutch assy	1	
15A	157FMI.05-00	Clutch assy	1	

FIG.E7

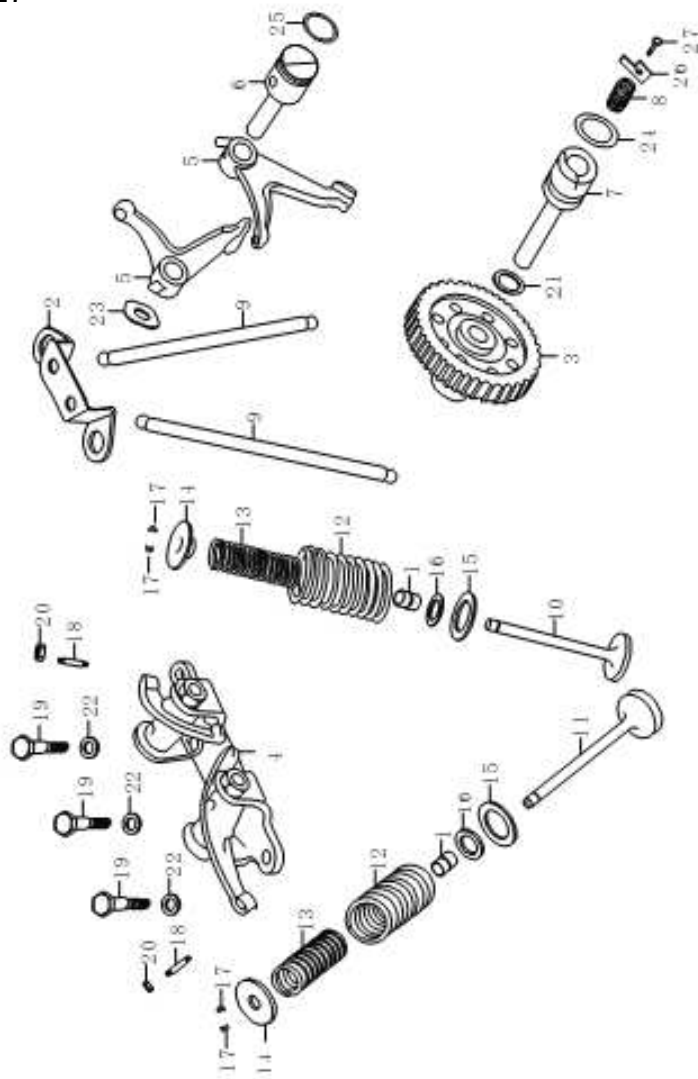

157FMI

E 7

FIG.E7

РАСПРЕДВАЛ / КЛАПАНА

Ref.No.	Part No.	Description	Q'ty	Remarks
1	244FMI.02-25	Valve seal	2	
2	157FMI.02-10	Push rod support	1	
3	157FMI.02.1-00	Camshaft	1	
4	157FMI.02.3-00A	Rocker arm	1	
5	157FMI.02-14A	Driver arm	2	
6	157FMI.02-18A	Driver shaft	1	
7	157FMI.02-16A	Gear shaft	1	
8	157FMI.02-17A	Spring	1	
9	157FMI.02.4-00	Push rod	2	
10	157FMI.02-06A	Inlet valve	1	
11	157FMI.02-07A	Outlet valve	1	
12	157FMI.02-09	Exhaust valve spring	2	
13	157FMI.02-08	Inlet valve spring	2	
14	244FMI.02-23	Spring seat	2	
15	157FMI.02-26	Spring seat	2	
16	157FMI.02-25	Spring seat	2	
17	244FMI.02-39	Cone block	4	
18	K157FMI02.6-02	Screw	2	
19	157FMI.02-22	Bolt M8x28	3	
20	K157FMI02.6-01	Nut	2	

FIG.E7

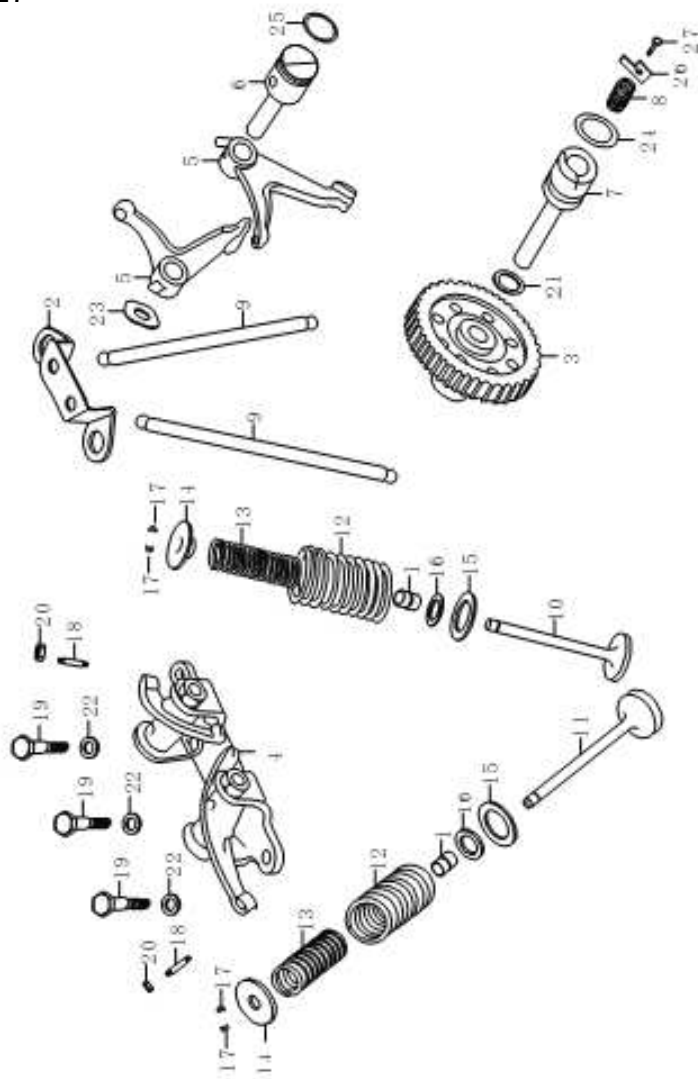

157FMI

E7

FIG.E7

РАСПРЕДВАЛІ / КЛАПАНА

Ref.No.	Part No.	Description	Q'ty	Remarks
21	N151FMG.06-08	Washer	1	
22	157FMI.02-24	Washer 8	3	
23	157FMI.02-27	Washer	1	
24	157FMI.02-21	O-Ring 20 x 2.5	1	
25	157FMI.02-19	O-Ring 17 x 2.5	1	
26	157FMI.02-15	Limit plate cam	1	
27	GB5787-86	Bolt M6 x 12	1	

FIG.E8

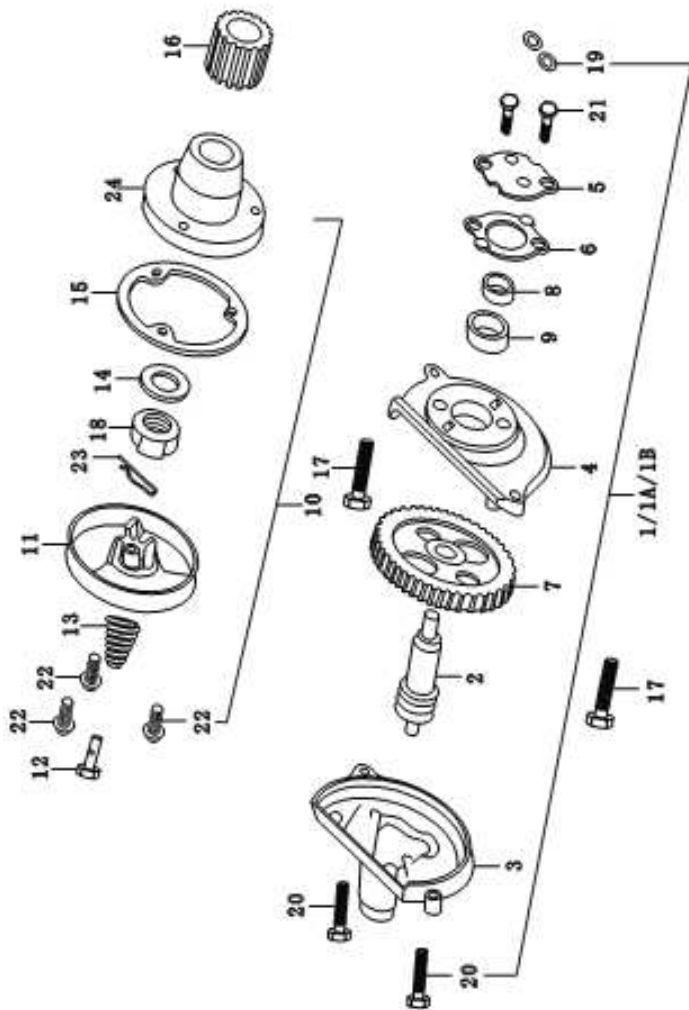

157FMI

E8

FIG.E8

MACJIO-HACOC

Ref.No.	Part No.	Description	Q'ty	Remarks
1	157FMI.12.2-00	Oil pump assy	1	
1A	157FMI.12.2-00A	Oil pump assy	1	
1B	157FMI.12.2-00B	Oil pump assy	1	
2	244FMI.12-01	Tactometer gear	1	
3	157FMI.12.2-01	Cover	1	
4	157FMI.12.2-02	Body	1	
5	157FMI.12.2-07	Pump piece	1	
6	157FMI.12.2-06	Gasket	1	
7	157FMI.12.2-03	Driveing gear, pump	1	
8	157FMI.12.2-05	Flow-in rotator	1	
9	157FMI.12.2-04	Flow-out rotator	1	
10	157FMI.12.1-00	Filter assy	1	
11	157FMI.12.1-01	Filter cover	1	
12	157FMI.12.1-02	Oil hole	1	
13	157FMI.12.1-03	Spring	1	
14	244FMI.05-12	Washer	1	
15	157FMI.12.1-05	Gasket	1	
16	157FMI.03-14	Driven gear	1	
17	GB819-85	Screw M6x30	2	
18	157FMI.12-05	Nut	1	

FIG.E8

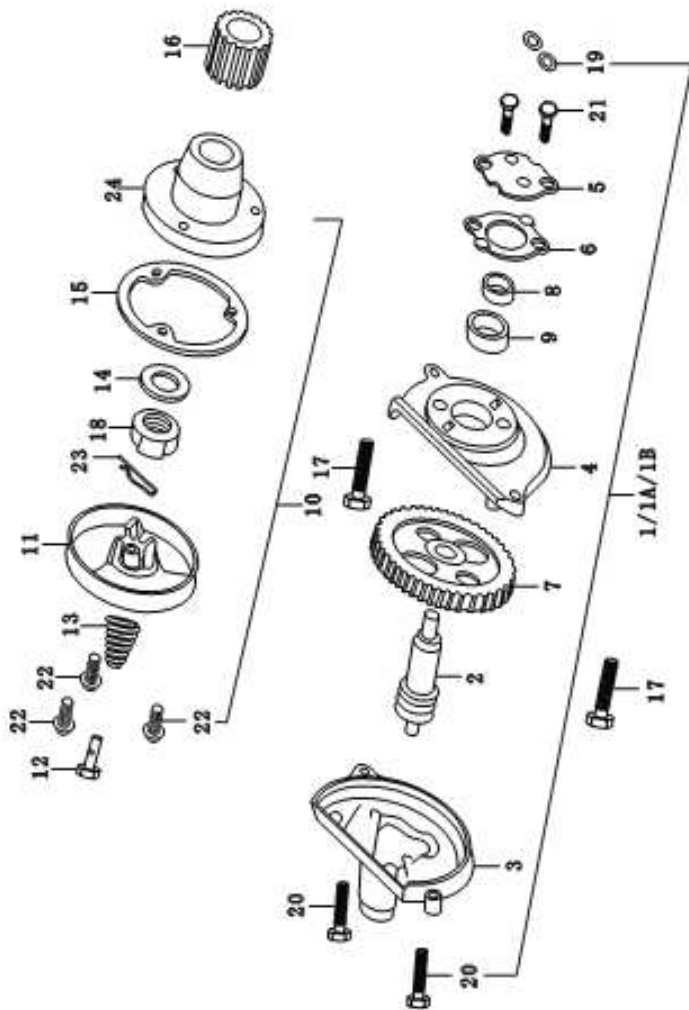

157FMI

E8

FIG.E8

MACIIO-HACOC

Ref.No.	Part No.	Description	Q'ty	Remarks
19	157FMI.12-04	O-Ring 9.4 x 2.4	2	
20	GB5780-86	Bolt M5 x 24	2	
21	GB819-85	Bolt M4 x 12	2	
22	GB819-85	Bolt M5 x 12	3	
23	157FMI.12.1-04	Pin	1	
24	157FMI.12.1-06	Rotor	1	

FIG.E9

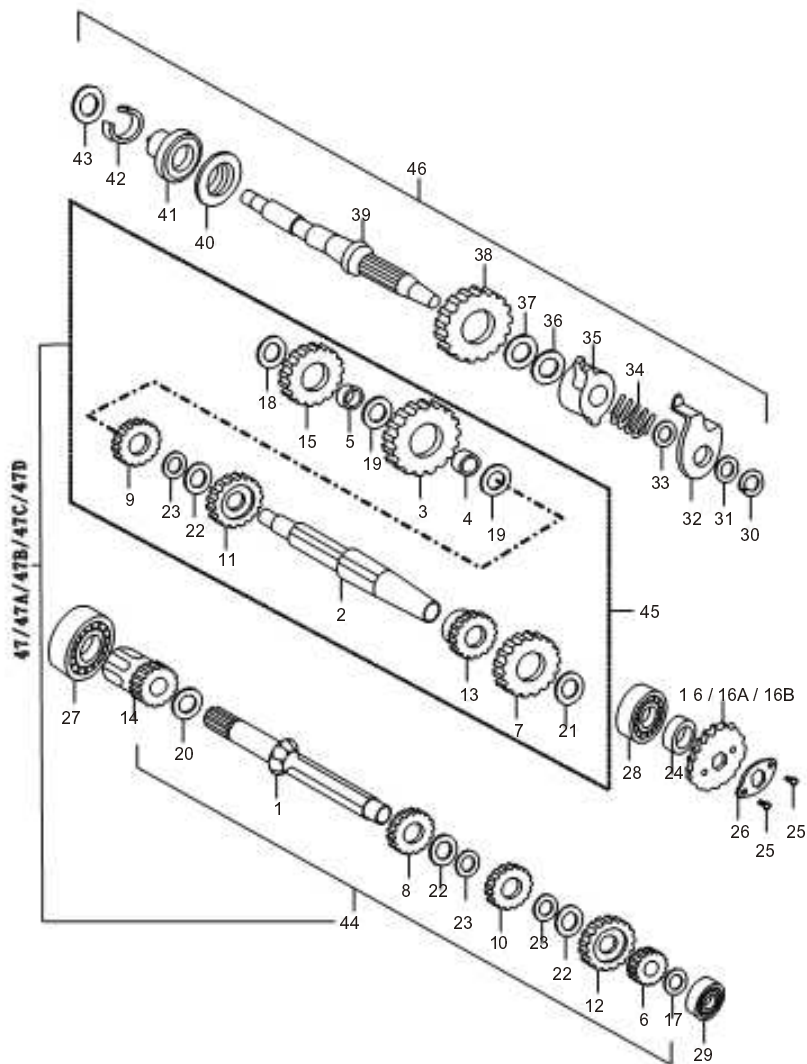

157FMI

E9

FIG.E9

ТРАНСМИССИЯ

Ref.No.	Part No.	Description	Q'ty	Remarks
1	157FMI.04-11	Driving shaft	1	
2	157FMI.04-04	Driven shaft	1	
3	157FMI.04.1-01	Driven shaft (1 th gear)	1	
4	157FMI.04.1-02	Bush	1	
5	157FMI.04.3-02	Bush	1	
6	157FMI.04-02	Driving shaft (2 th gear)	1	
7	157FMI.04-05	Driven shaft (2 th gear)	1	
8	157FMI.04-12	Driving shaft (3 th gear)	1	
9	157FMI.04-08	Driven shaft (3 th gear)	1	
10	157FMI.04-13	Driving shaft (4 th gear)	1	
11	157FMI.04-07	Driven shaft (4 th gear)	1	
12	157FMI.04-01	Driving shaft (5 th gear)	1	
13	157FMI.04-06	Driven shaft (5 th gear)	1	
14	157FMI.04.3-00	Starting gear	1	
15	157FMI.04.2-00	Starting gear	1	
16	157FMI.04-03	Driving shaft	1	15T
16A	157FMI.04-03A	Driving shaft	1	14T
16B	157FMI.04-03B	Driving shaft	1	12T
17	244FMI.04-13	Push-washer	1	
18	157FMI.04-10	Push-washer	1	

FIG.E9

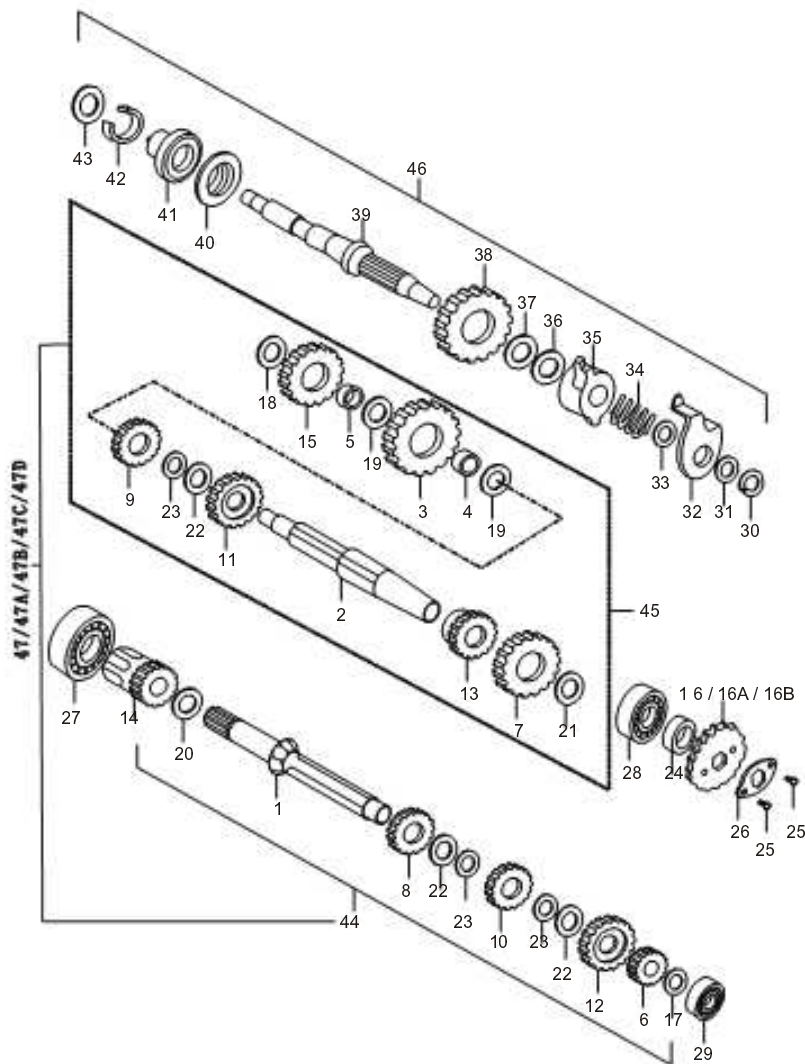

157FMI

E9

FIG.E9

ТРАНСМИССИЯ

Ref.No.	Part No.	Description	Q'ty	Remarks
19	157FMI.04-09	Push-washer	2	
20	157FMI.04-14	Push-washer	1	
21	157FMI.04-15	Washer	1	
22	244FMI.04-19	Spring washer	3	
23	244FMI.04-20	Circlip	3	
24	244FMI.04-07	Oil seal 20x34x7	1	
25	GB5781-86	Bolt M6x10	2	
26	244FMI.04-05	Locating plate	1	
27	GB276-64	Bearing 6006	1	
28	GB276-64	Bearing 6202-Z	1	
29	GB276-64	Bearing 6204	1	
30	157FMI.06-01	Washer	1	
31	GB894.1-86	Circlip 20	2	
32	157FMI.06.1-00	Guide piece	1	
33	157FMI.06-03	Washer	1	
34	157FMI.06-02	Ratchet kick start spring	1	
35	157FMI.06-11	Ratchet kick start	1	
36	GB894.1-86	Circlip16	1	
37	157FMI.06-10	Washer	2	
38	157FMI.06-04	Starting gear	1	

FIG.E9

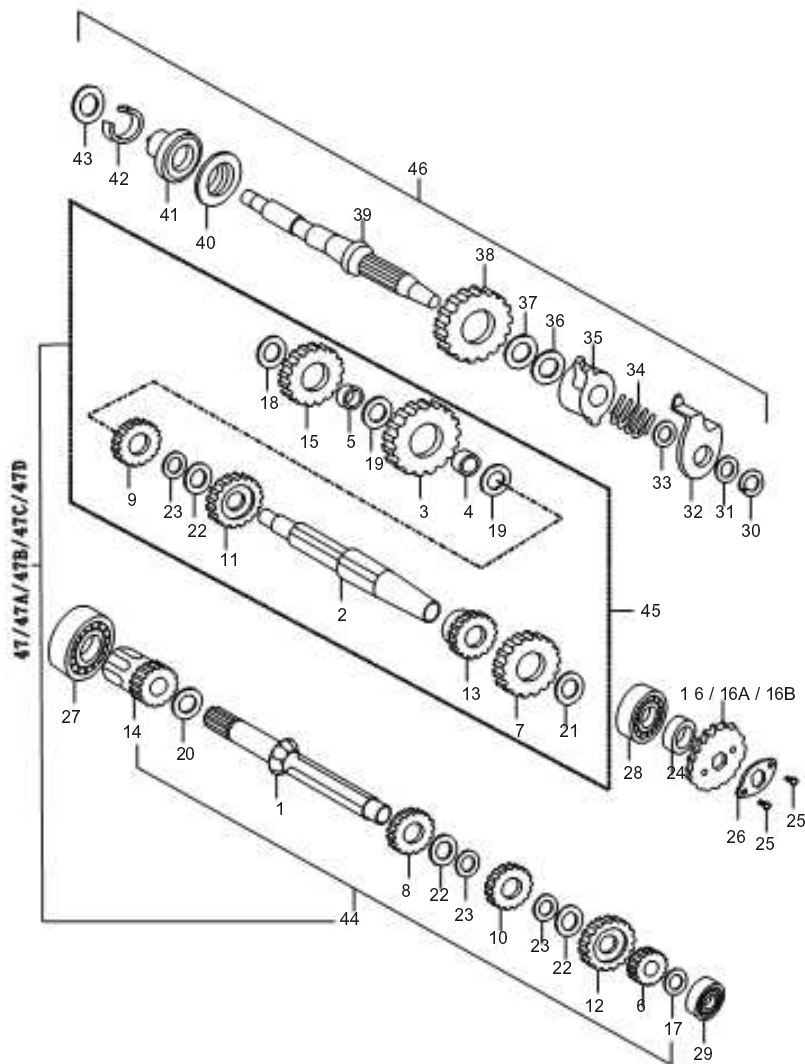

157FMI

E 9

FIG.E9

ТРАНСМИССИЯ

Ref.No.	Part No.	Description	Q'ty	Remarks
39	157FMI.06-08	Starting shaft	1	
40	157FMI.06-05	Circlip	1	
41	157FMI.06-09	Start-spring	1	
42	157FMI.06-06	Sleeve	1	
43	K157FMI06-09	Washer	1	
44		Driving shaft assy	1	
45		Driven shaft assy	1	
46	157FMI.06-00	Starting shaft assy	1	
47	157FMI.04-00	Driving and driven shaft assy	1	
47A	157FMI.04-00A	Driving and driven shaft assy	1	
47B	157FMI.04-00J	Driving and driven shaft assy	1	
47C	157FMI.04-00AJ	Driving and driven shaft assy	1	
47D	157FMI.04-00D	Driving and driven shaft assy	1	

FIG.E10

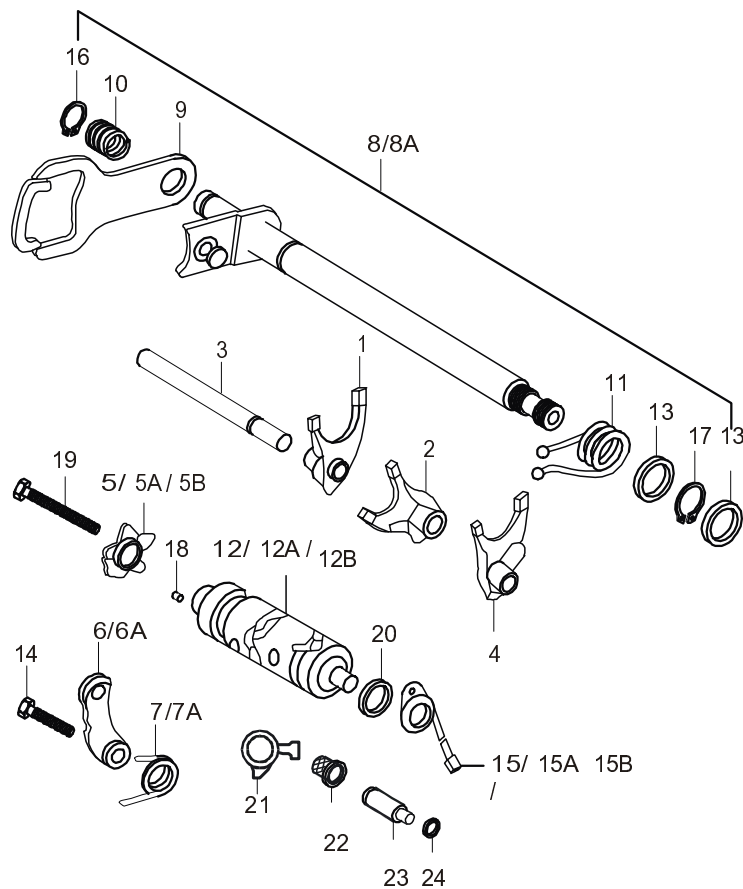

157FMI

E10

FIG.E10

МЕХАНИЗМ ВЫБОРА ПЕРЕДАЧ

Ref.No.	Part No.	Description	Q'ty	Remarks
1	157FMI.10-13	Controlling piece	1	
2	157FMI.10-02B	Controlling piece	1	
3	244FMI10-05	Shaft	1	
4	157FMI.10-12	Controlling piece	1	
5	157FMI.10-03B	Controlling piece	1	
5A	157FMI.10-03C	Controlling piece	1	
5B	157FMI.10-03D	Controlling piece	1	
6	157FMI.10.1-00B	Limit block	1	
6	157FMI.10.1-00C	Limit block	1	
7	157FMI.10-01A	Spring	1	
7A	157FMI.10-01C	Spring	1	
8	157FMI.10.2-00A	Shaft assy	1	
8A	157FMI.10.2-00C	Shaft assy	1	
9	157FMI.10-05A	Locate piece	1	
10	157FMI.10-04A	Spring	1	
11	157FMI.10-06A	Spring	1	
12	157FMI.10-08A	Drum	1	
12A	157FMI.10-08A	Drum	1	
12B	157FMI.10-08E	Drum	1	
13	157FMI.10-07A	Washer	2	

FIG.E10

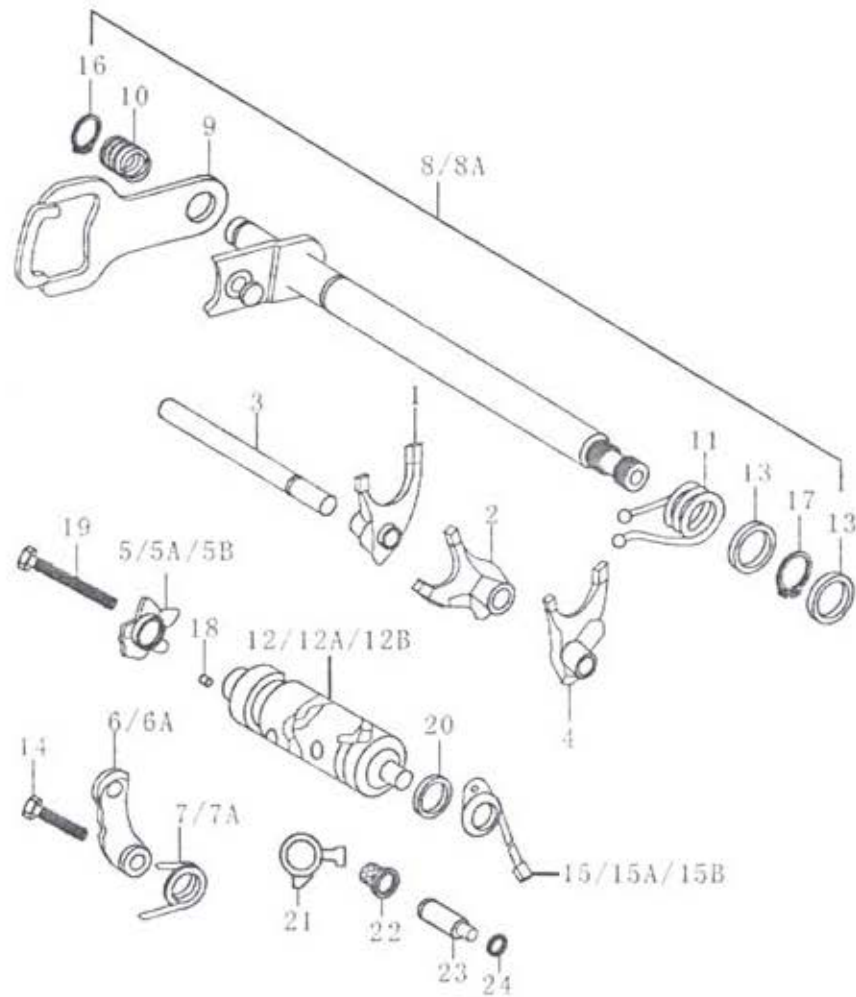

E10
FIGE10
SHAFT DEVICE

Ref.No.	Part No.	Description	Q'ty	Remarks
14	GB5781-86	Bolt M6×16	1	DZn5.DC
15	157FMI.10.3-00B	Switch	1	国际五档
15A	157FMI.10.3-00C	Switch	1	循环五档
15B	157FMI.10.3-00D	Switch	1	伊朗专用
16	GB894.1-86	Cieclip 12	1	
17	GB894.1-86	Circlip 14	1	
18	GB309-84	Pin 4×9.8	1	
19	GB5781-86	Bolt M6×25	1	DZn5.DC
20	157FMI.10-14B	Oil seal 14×22×5	1	
21	157FMI.10-09E	Washer	1	伊朗专用
22	157FMI.10-11E	Cushion	1	伊朗专用
23	244 FMI.10.4-00	Interface	1	伊朗专用
24	244 FMI.10-14	O-Ring 7×1.7	1	伊朗专用

FIG.E11

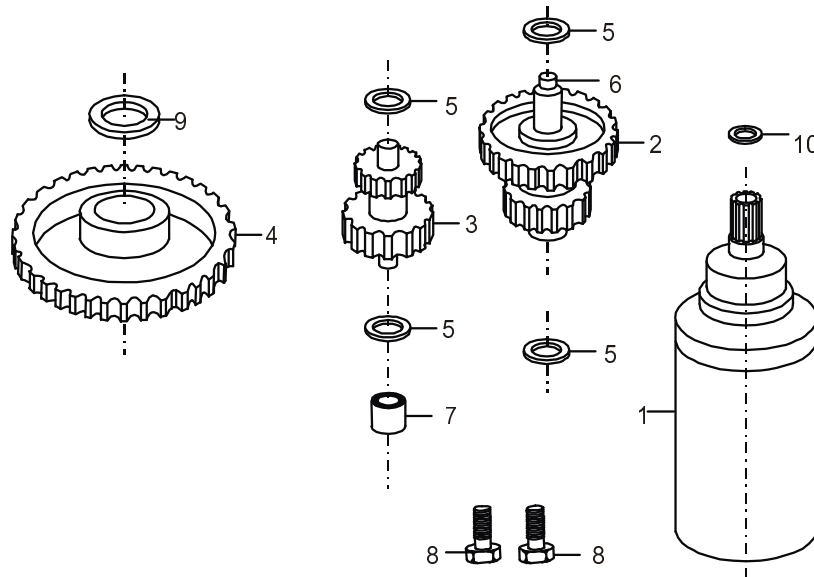

E11

FIG.E11

MOTOP CTAPTEPA

Ref.No.	Part No.	Description	Q'ty	Remarks
1	157FMI.06.D.2-00	Starting motor assy	1	
2	157FMI.06.D-01	Double I	1	
3	157FMI.06.D-05	Gear assy II	1	
4	157FMI.06.D.3-00	Plate gear assy	1	
5	157FMI.06.D-02	Washer thrust	4	
6	157FMI.06.D-03	Live axle	1	
7	HK101410	Needle bearing	2	
8	GB5787-86	Bolt M6 x 28	2	
9	157FMI.06.D-10	Oil seal 34 x 50 x 7	1	
10	157FMI.06.D.2-01	O-Ring	1	

157FMI

FIG.E12

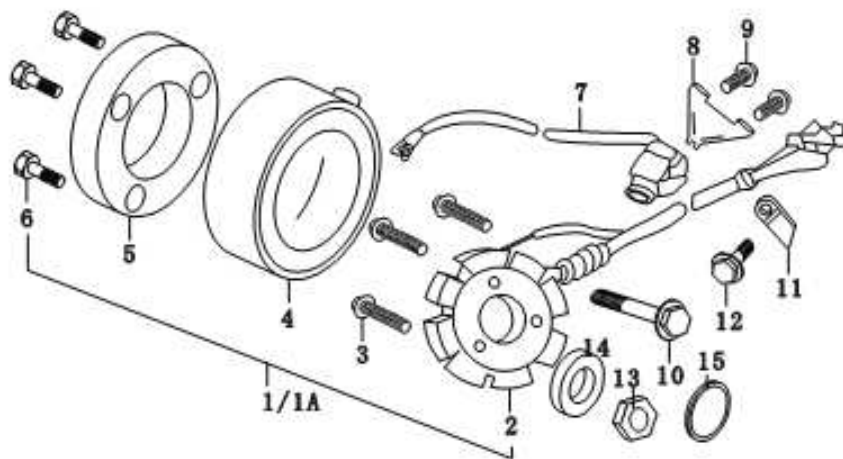

E12

FIG.E12

MAGHETTO

Ref.No.	Part No.	Description	Q'ty	Remarks
1	157FMI.07.1-00	Magnetor assy	1	
1A	157FMI.07.1-00C	Magnetor assy	1	
2	157FMI.07.1-01	Stator assy	1	
3	GB5787-86	Screw M5x25	3	
4	157FMI.07.1-02	Rotor assy	1	
5	157FMI.06D.1-00	Director	1	
6	GB5787-86	Bolt M6x20	3	
7	157FMI.07.2-00A	Transmitter	1	
7A	157FMI.07.2-00F	Transmitter	1	
8	157FMI.07.3-00	Clamp, transmitter wire	1	
9	GB5781-86	Screw M5x12	2	
10	244FMI.07-03	Screw	1	
11	157FMI.01-09	Clamp	1	
12	GB5787-86	Screw M6x16	1	
13	P152QMI.06.04-15	Stud	1	
14	157FMI.07-02	Oil seal	1	
15	157FMI.07-01	O-Ring	1	

157FMI

FIG.E13

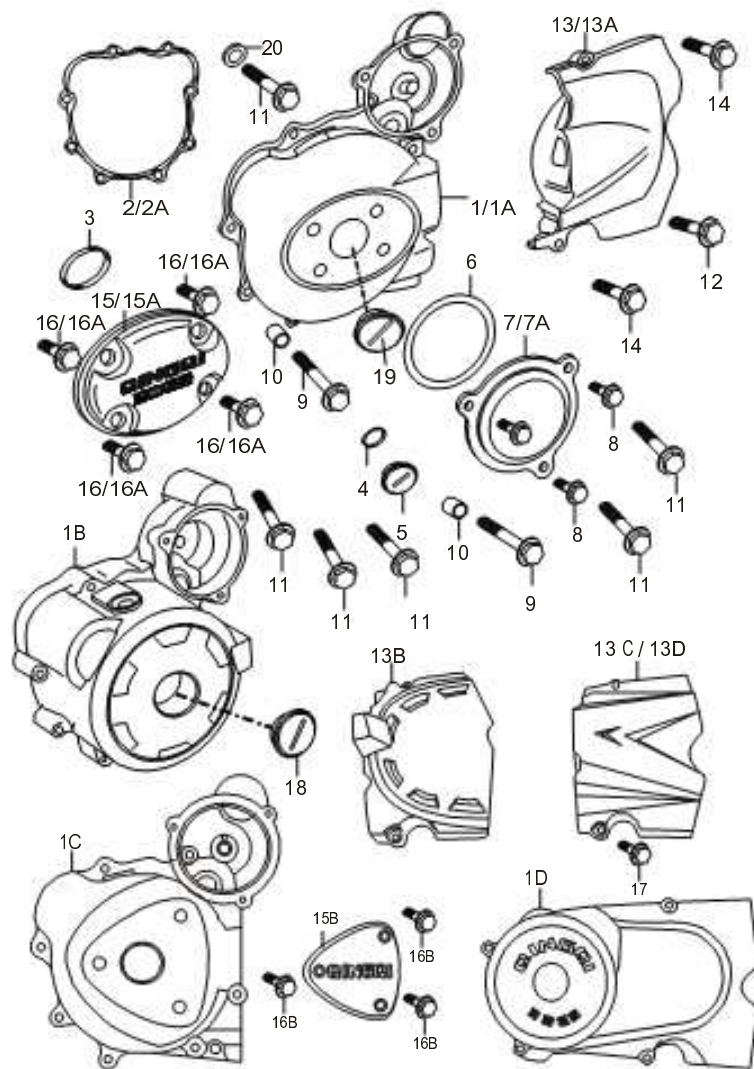

157FMI

E13

FIG.E13

КРЫШКА КАРТЕРА ЛЕВАЯ

Ref.No.	Part No.	Description	Q'ty	Remarks
1	157FMI.01-01	Left hand case cover	1	
1A	157FMI.01-01A	Left hand case cover	1	
1B	157FMI.01-01E	Left hand case cover	1	
1C	157FMI.01-01F	Left hand case cover	1	
1D	157FMI.01-01B	Left hand case cover	1	
2	157FMI.01-02	Packing ring, left front cover	1	
2A	157FMI.01-02A	Packing ring, left front cover	1	
3	244FMI.01-06	O ring 27.4 x 2.4	1	
4	244FMI.01-20	O ring 13.8 x 2.5	1	
5	157FMI.01-19	Cover inspection hole	1	
6	157FMI.01-07	O-Ring 63x3	1	
7	157FMI.01-08	Cover gear	1	
7A	157FMI.01-08A	Cover gear	1	
8	GB5787-86	Bolt M6 x 20	3	
9	GB5787-86	Bolt M6 x 50	2	
10	157FMI.01-16	Pin	2	
11	GB5787-86	Bolt M6 x 40	5	
12	GB5787-86	Bolt M6 x 25	1	
13	157FMI.01-6	Chain cover	1	
13A	157FMI.01-6 A	Chain cover	1	

FIG.E13

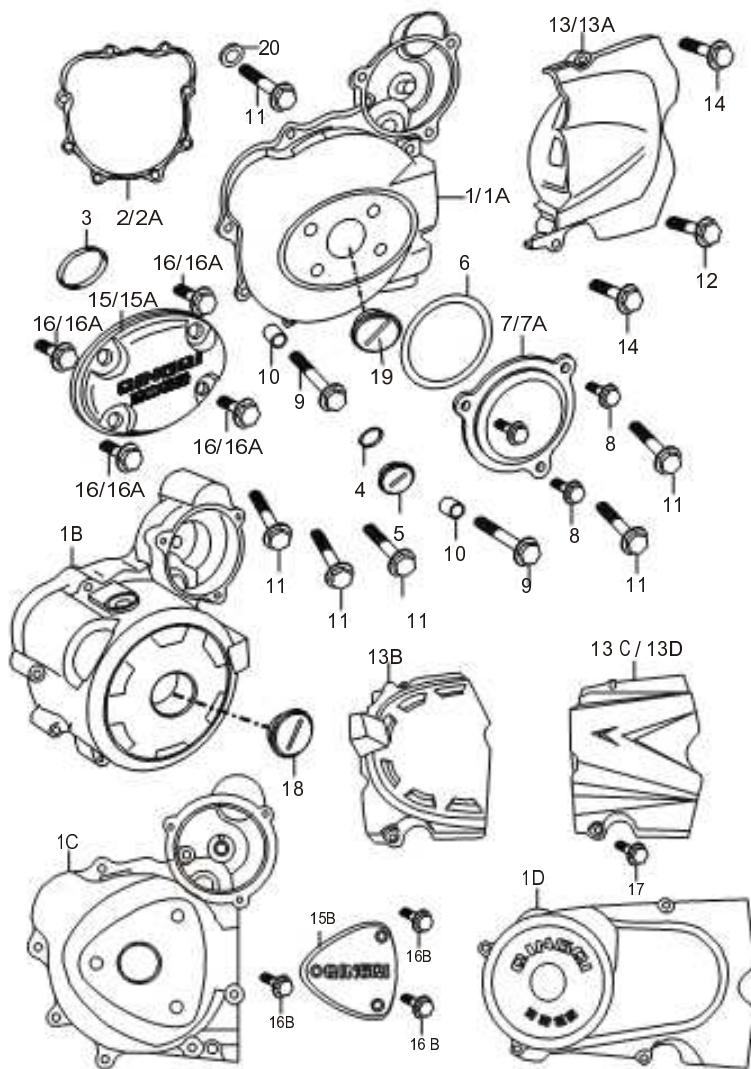

157FMI

E13

FIG.E13

КРЫШКА КАРТЕРА ЛЕВАЯ

Ref.No.	Part No.	Description	Q'ty	Remarks
13B	157FMI.01-6D	Chain cover	1	
13C	157FMI.01-6F	Chain cover	1	
13D	157FMI.01-6L	Chain cover	1	
14	GB5787-86	Bolt M6 x 28	2	
15	157FMI.01-14	Left cover	1	
15A	157FMI.01-14A	Left cover	1	
15B	157FMI.01-20F	Left cover	1	
16	GB5787-86	Bolt M6 x 14	4	
16A	GB5787-86	Bolt M6 x 16	4	
16B	GB820-2000	Bolt M6 x 10	3	
17	GB5787-86	Bolt M6 x 35	4	
18	157FMI01-20	Bolt	1	
19	244FMI.01-05	Bolt	1	
20	K157FMI.01.4-00	Gaasket	1	

FIG.E14

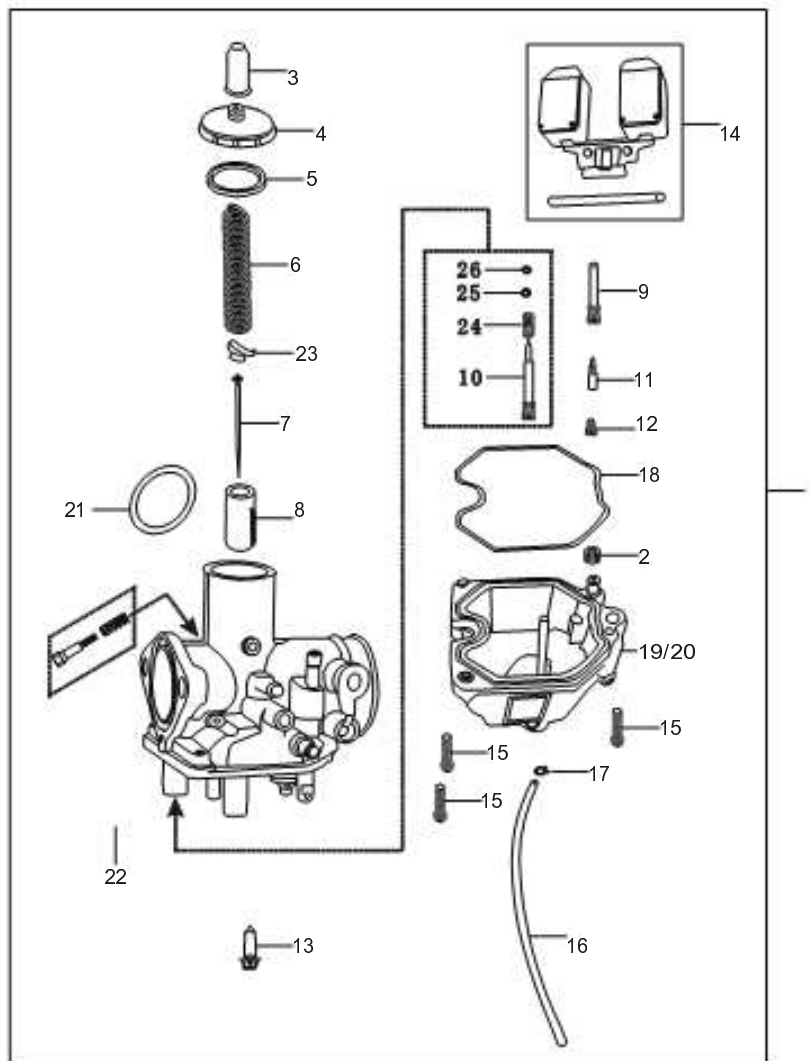

157FMI

E 14

FIG.E14

КАРБЮРАТОР

Ref No	Part No	Description	Q'ty	Remarks
1	157FMI.08-00	Carbiuretor	1	
2	157FMI.08.1-00	Float chamber Cap,	1	
3	157FMI.08-1	Cable sealing Cap	1	
4		valve	1	
5		O Ring seal	1	
6	157FMI.08-2	Spring	1	
7	157FMI.08.3-00	Needle jet set	1	
8	157FMI.08-3	Valve, air	1	
9	157FMI.08-4	Idlejet	1	
10	157FMI.08.4-00	Adjuster idle	1	
11	157FMI.08-5	mixture Holder	1	
12	157FMI.08-6	needle jet Main jet	1	
13	157FMI.08-7	Needle valve	1	
14	157FMI.08.5-00	Float	1	
15	GB818-85	Bolt M4x16	3	
16	157FMI.08-8	Tube overflow	1	
17	157FMI.08-9	Lock ring	1	
18	157FMI.08-10	Gasket	1	
19		O Ring	1	
20		Drain bolt	1	

FIG.E14

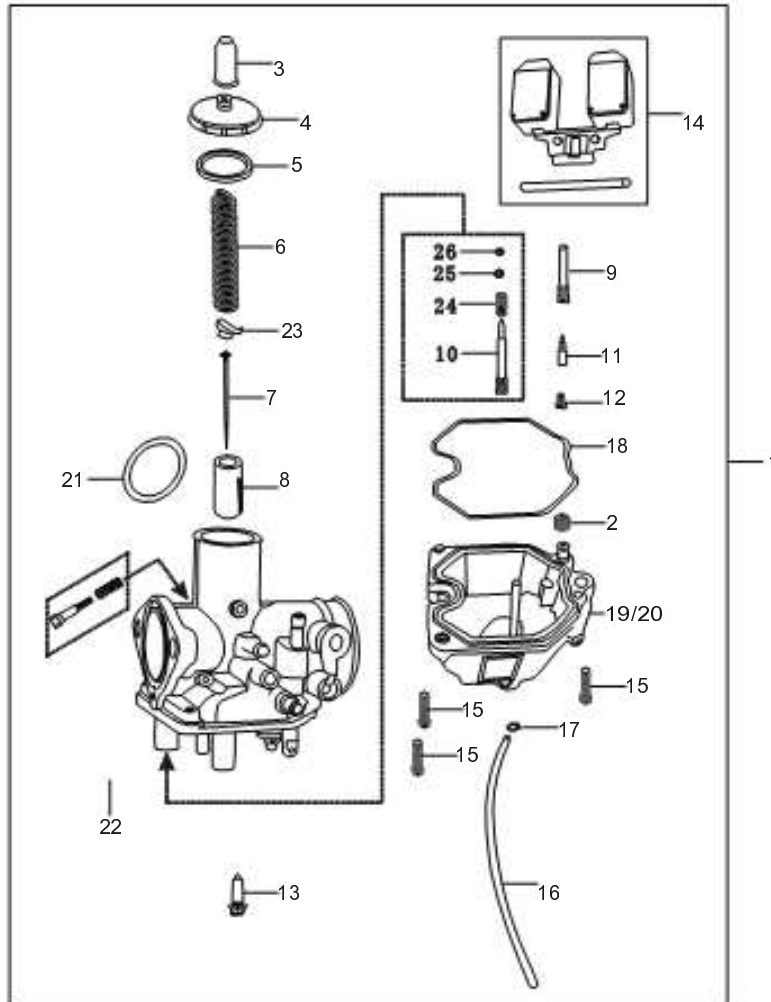

E14

FIG.E14

КАРБИОРАТОР

Ref No	Part No	Description	Q'ty	Remarks
21	157FMI.08-11	O Ring	1	
22		Body, carburetor	1	
23		Clamp	1	
24		Spring	1	
25		Spring washer	1	
26		Washer	1	

157FMI

FIG.E15

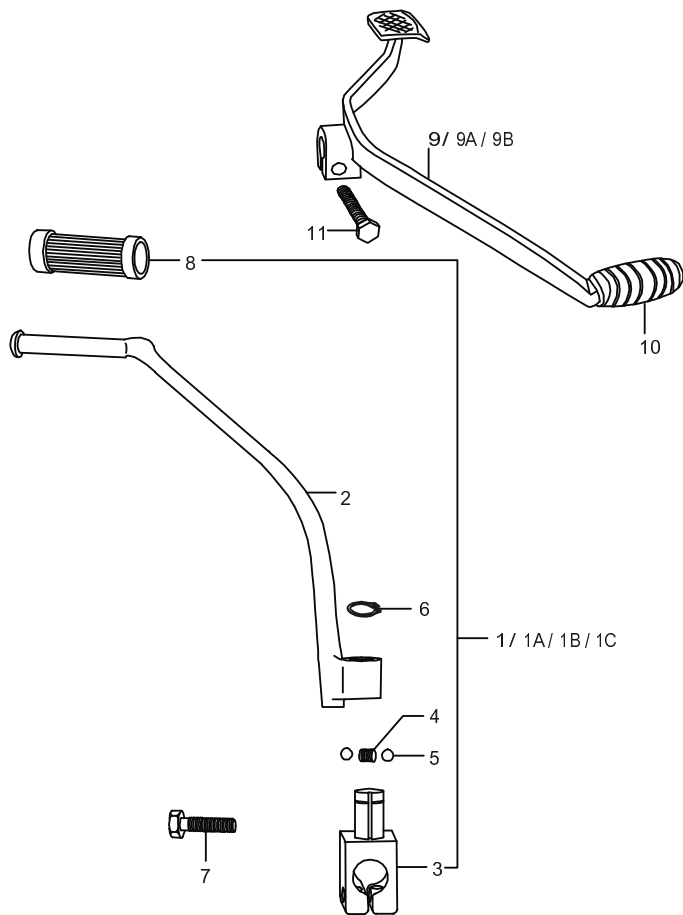

157FMI

E15

FIG.E15

ЛАПКА КИК- СТАРТЕРА

Ref.No.	Part No.	Description	Q'ty	Remarks
1	157FMI.06.2-00	Kick start lever assy	1	
1A	157FMI.06.2-00A	Kick start lever assy	1	
1B	157FMI.06.2-00B	Kick start lever assy	1	
1C	157FMI.06.2-00C	Kick start lever assy	1	
2	157FMI.06.2-01A	Kick start lever	1	
3	157FMI.06.2-03	Spling seat	1	
4	157FMI.06.2-02	Spring	1	
5	GB308-84	Ball	2	
6	GB894.1-86	Ring 14	1	
7	GB5781-86	Bolt M8 x 25	1	
8	157FMI.06.02-04	Rubber, kick start	1	
9	157FMI.10.4-00	Gear shift lever	1	
9A	157FMI.10.4-00A	Gear shift lever	1	
9B	157FMI.10.4-00B	Gear shift lever	1	
10	157FMI(-7A).10-01	Rubber shift gear	1	
11	GB5781-86	Bolt M6 x 20	1	

FIG.E16

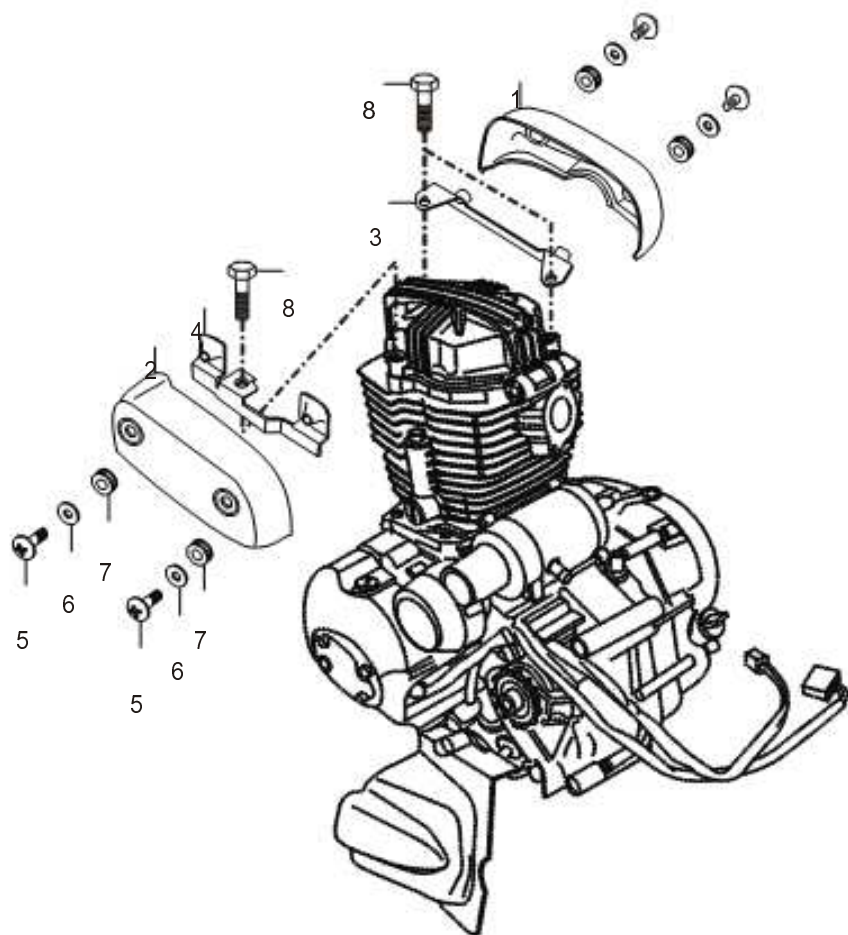

E16

FIG.E16

КРЫШКА ДВИГАТЕЛЯ

Ref.No.	Part No.	Description	Qty	Remarks
1	157FMI.02-29	Right cover, enging	1	
2	157FMI.02-28	head Left cover, enging	1	
3	157FMI.02.10-00	head Right plate	1	
4	157FMI.02.9-00	Left plate	1	
5	157FMI.07	Screw	4	
6	157FMI.06	Washer 6.3x22x .2	4	
7	157FMI.02-30	Cushion	4	
8	GB5787-86	Bolt M6 x30	3	

157FMI